

NOTES:

1. ALL SUBSTRATES TO RECEIVE TEOBLOC SA MUST BE PRIMED WITH ULTRA-GUARD PRIMER.
2. A 9" REINFORCING STRIP OF TEOBLOC SA IS APPLIED AT 90 DEGREE CHANGES IN PLANE.
3. FIRMLY ROLL MEMBRANE WITH COUNTERTOP-STYLE ROLLER IMMEDIATELY AFTER INSTALLATION.
4. SEAMS WITHIN 12" OF CHANGE-IN-PLANE MUST BE SEALED WITH ULTRA-GUARD EFS.
5. SEE SPECIFICATIONS FOR COMPLETE REQUIREMENTS.

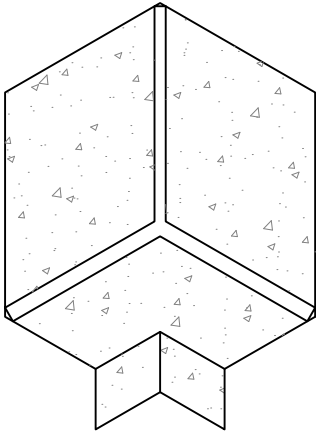

STEP 1
 AT HORIZONTAL AND VERTICAL CORNERS, APPLY FILLET BEAD OF ULTRA-GUARD EFS TO CLEANED, PREPARED AND PRIMED SUBSTRATE

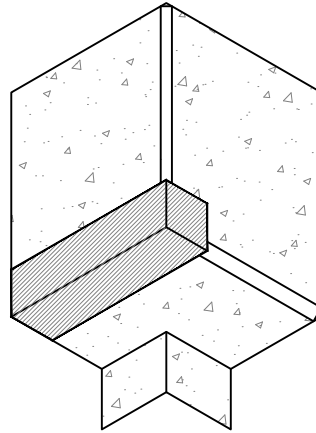

STEP 2
 PRESTRIP TRANSITION AREA AS SHOWN WITH 9" MIN. WIDE TEOBLOC SA PAST INSIDE CORNERS

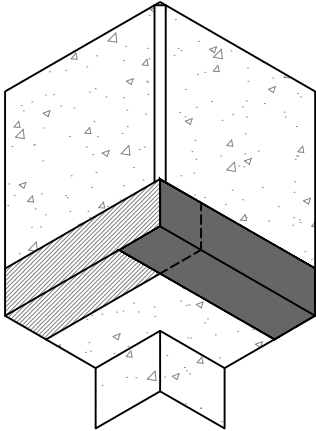

STEP 3
 CONTINUE TO PRESTRIP TRANSITION AREA AS SHOWN WITH 9" MIN. WIDE TEOBLOC SA INTO CORNER. SEAL CUT EDGES WITH ULTRA-GUARD EFS

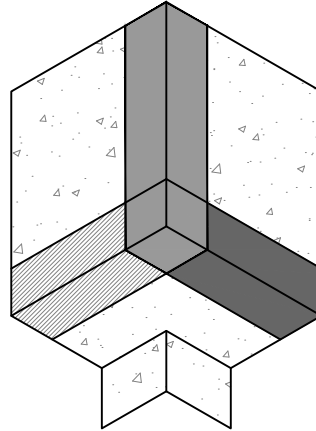

STEP 4
 APPLY 9" MIN. WIDE TEOBLOC SA VERTICALLY AS SHOWN TO INSIDE CORNERS

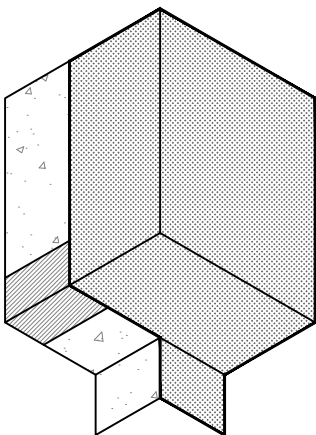

STEP 5
 EXTEND TEOBLOC SA A MIN. OF 8" PAST INSIDE CORNER AND DOWNWARD OVER FOOTING AS SHOWN. CREATE FLAP IN EXCESS MEMBRANE AS SHOWN AND FOLD DOWNWARD ONTO HORIZONTAL SURFACE. SEAL EDGES WITH ULTRA-GUARD EFS

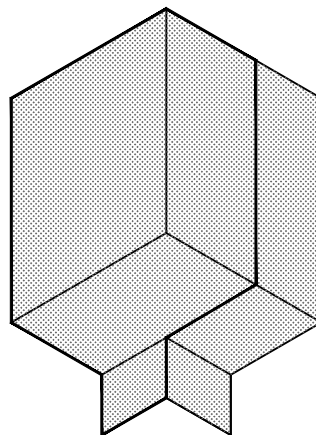

STEP 6
 CONTINUE FIELD APPLICATION WITH TEOBLOC SA EXTENDING DOWNWARD OVER FOOTING AS SHOWN. SEAL ALL SEAMS AND TERMINATIONS LOCATED WITH 12" OF CHANGE-IN-PLANE WITH ULTRA-GUARD EFS

DRAWINGS ON 8 1/2"x11 TITLE BLOCKS ARE NOT TO SCALE.

TegoBloc SA

INSIDE CORNER DETAIL



DETAIL ID:	SA-03
REPRESENTATIVE:	
DATE:	SHT: OF